

4 AND 2 DRUM SPILL PALLET AND HARD COVER MODELS #4064 AND #4062 READ ALL ASSEMBLY INSTRUCTIONS BEFORE USE

THANK YOU FOR PURCHASING YOUR ENPAC SPILL PALLET HARD COVER. THESE EASY INSTALLATION INSTRUCTIONS WILL ASSURE YOU STABLE AND SPACE-EFFICIENT STORAGE.

RECOMMENDED TOOLS:

Cordless Drill (12v or higher)
Hex Head to Socket Drive transition
½" Socket

SHIPPED PRODUCT CONTAINS THE FOLLOWING:

<u>QTY</u>	<u>Part</u>
(2)	SIDEWALLS (Part A)
(1)	UPPER SUPPORT BRACE (Part B)
(2)	LOWER SUPPORT LEG (Part C)
(6)	5/16" x 5.5" LONG HEX HEAD LAG SCREW (ZINC PLATED) (Part D)
(6)	5/16" X 1" FENDER WASHERS (ZINC PLATED) (Part E)
(1)	SPILLPALLET WITH TWO LOCKING HASPS (Part F)
(1)	TAMBOUR DOOR WITH ALUMINUM EXTRUSION ON BOTH ENDS (Part G)
(1)	TAMBOUR DOOR WITH ALUMINUM EXTRUSION ON ONE END (Part H)
(2)	STANDARD BLACK GRATES, (1) FOR PART #4062 ONLY (Part I)
(1)	ASSEMBLY INSTRUCTION SHEET

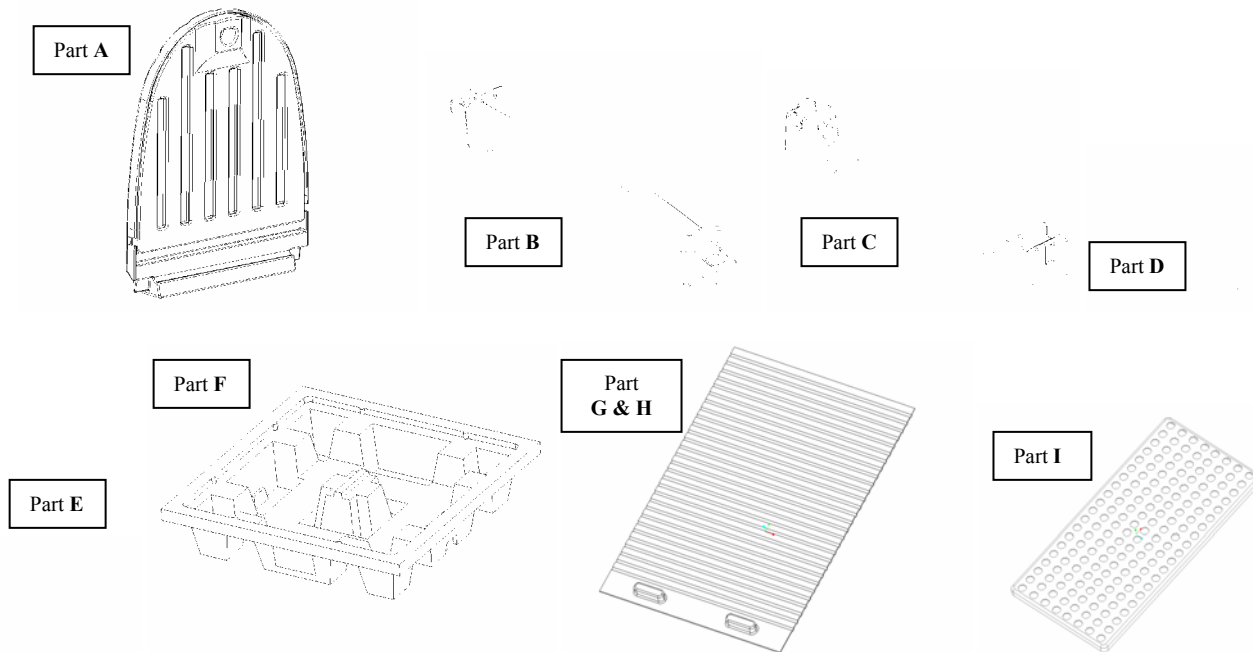

ENPAC RECOMMENDS

- ◆ ENPAC CORP. RECOMMENDS ASSEMBLING THIS PRODUCT WITH TWO PEOPLE, BUT NOT REQUIRED.
- ◆ ENPAC ALSO RECOMMENDS THAT UPON RECEIVING THIS PRODUCT YOU SHOULD MAKE SURE THAT ALL PARTS ARE PRESENT PER THIS INSTRUCTION SHEET BEFORE ASSEMBLING.
- ◆ AFTER USING YOUR SPILLPALLET COVER, ENPAC RECOMMENDS THAT YOU COAT THE TAMBOUR DOOR TRACKS WITH SILICONE (ANY OFF THE SHELF SILICONE WILL BE FINE) FROM TIME TO TIME TO ENSURE SMOOTH SLIDING OF THE DOORS.

ASSEMBLY INSTRUCTIONS:

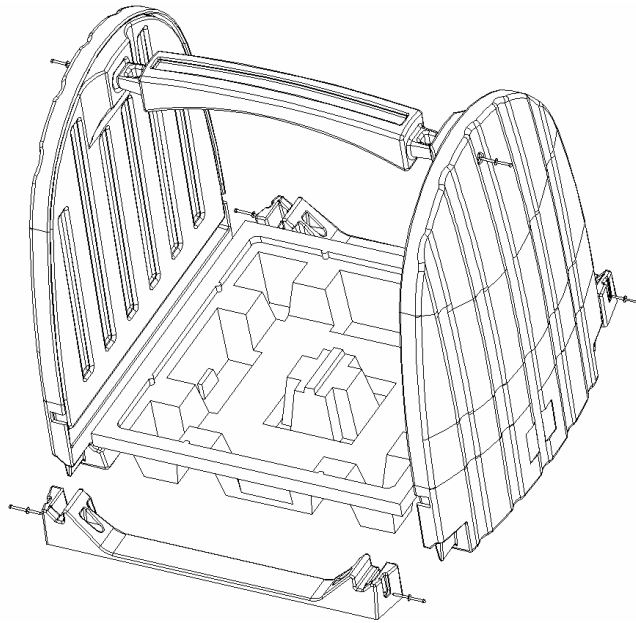

1) Stand Part (A), Hard Cover Side Wall, upwards. (See fig.1)

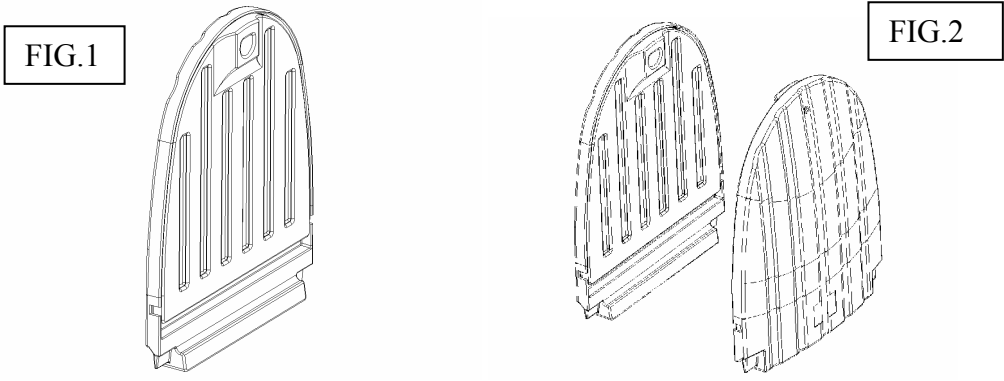

2) Repeat step 1, directly opposite Part (A). (See fig.2)

3) With Part (C), Lower Leg Brace, placed flat on ground in front of Parts (A), firmly press end pieces onto each corner of Part (A). (See fig.3 & 3a)

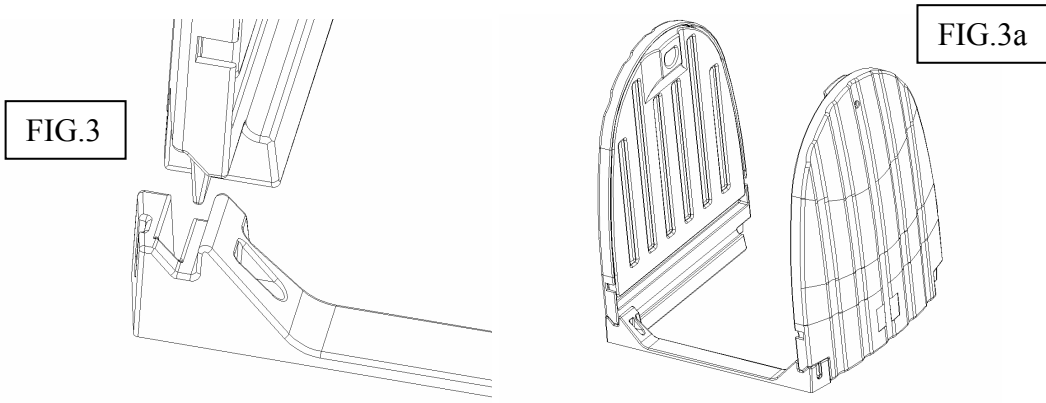

- 4) Repeat step 3, with remaining Part (C).
- 5) Drive Part (D), 5/16" x 5 1/2" long lag screw with Part (E) fender washer, into Part (C) till secure as shown. **WARNING DO NOT OVERTIGHTEN SCREW.** (See fig.4)

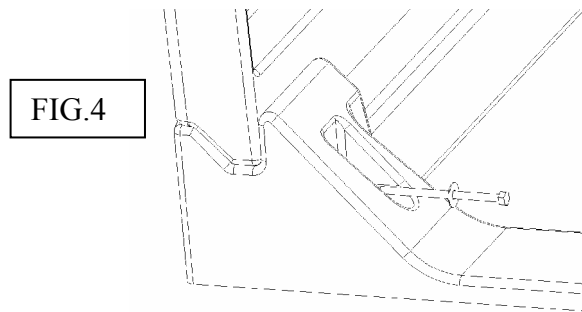

- 6) Repeat step 5. for the three (3) remaining corners.
- 7) Next insert Part (F), the Spill Pallet, at an angle in between the sidewalls with hasps facing forward.
- 8) Press down firmly Part (F), the Spill Pallet, until it is secured in space provided on both sidewalls. Place Part (I), the grates, onto Part (F). (See fig.5 & 5a)

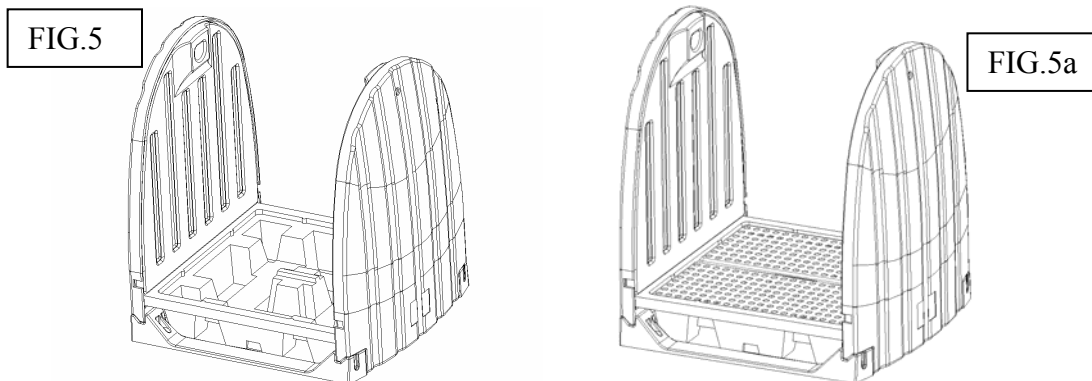

- 9) Next insert Part (B), top brace, into spaces provided on Part (A), sidewall. (See fig.6)

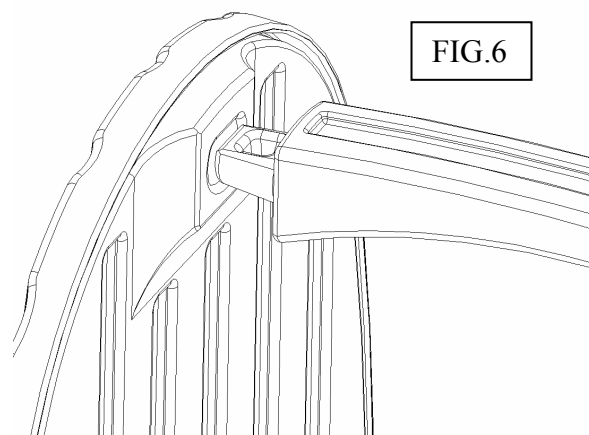

- 10) Fasten Part (B), top brace, with remaining two Parts (D) and Parts (E), 5/16" x 5 1/2" lag screws and fender washers, on each sidewall. **WARNING DO NOT OVERTIGHTEN SCREW.** (See fig.7 & 7a)

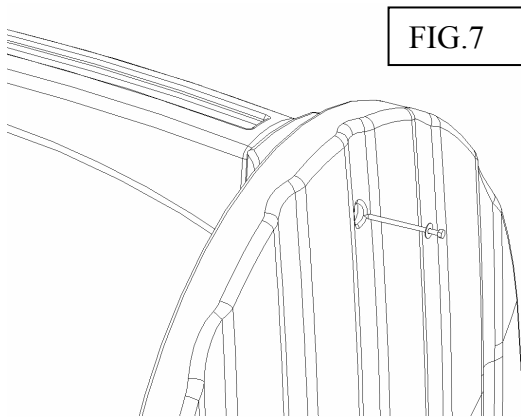

FIG.7

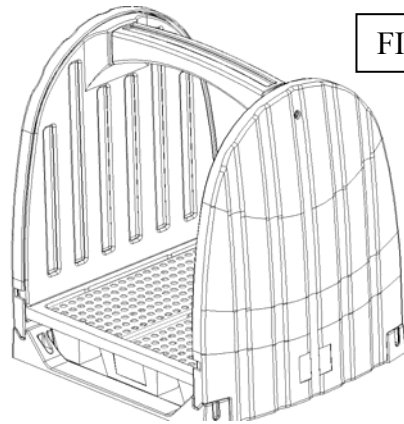

FIG.7a

11) Place Part (H), tambour door with one extrusion, down on the floor handles up, in front of the unit. (See fig.8)

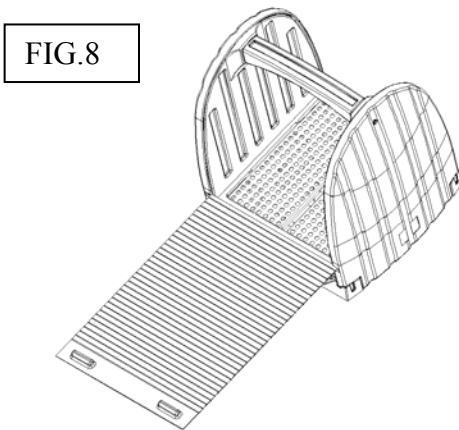

FIG.8

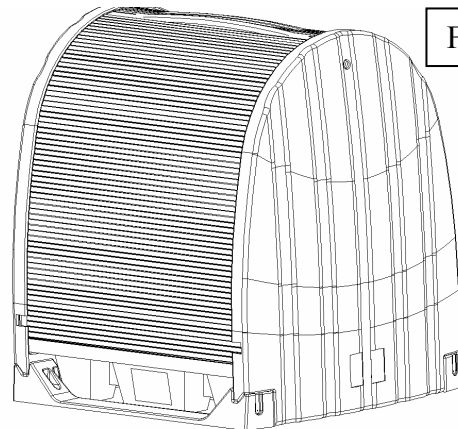

FIG.9

12) Ease Part (H), the tambour door with aluminum extrusion on one end, into groves provided and push door entirely in until it is securely inserted into the Hard Cover Side Walls. (See fig.9)

13) Repeat steps 11. and 12. with Part (G), tambour door with aluminum extrusions on both ends, from the opposite side of the Hard Cover Side Walls, making sure Part (G) is over top of Part (H). (See fig.10)

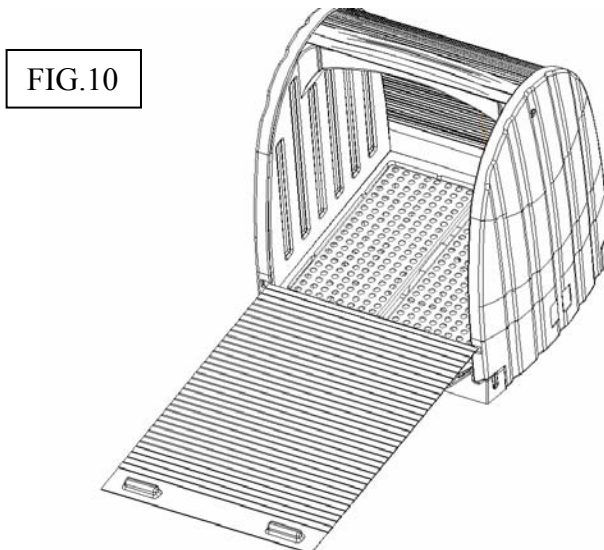

FIG.10

FOR MORE INFORMATION CONTACT ENPAC CUSTOMER SERVICE (800) 936-7229