



# UNIVERSAL CYLINDER BRACKET MODEL #7216-YE ASSEMBLY INSTRUCTIONS

## SHIPPED PRODUCT CONTAINS THE FOLLOWING:

- (1) UNIVERSAL CYLINDER BRACKET
- (1) 1 HEAVY DUTY STRAP ASSEMBLY

**NOTE: HARDWARE USED TO MOUNT THE UNIVERSAL CYLINDER BRACKET TO THE WALL OR MOUNTING SURFACE IS NOT INCLUDED. THE TYPE OF MOUNTING SURFACE WILL DETERMINE THE HARDWARE USED FOR INSTALLATION.**

## ENPAC RECOMMENDS

*FOR CONCRETE WALL: (2) 3/8" DIAMETER x 3-1/2" LONG LAG SCREW WITH SHORT MASONRY EXPANSION SHIELDS*

*FOR WOOD WALL: (2) 3/8" DIAMETER x 3-1/2" LONG LAG*

*FOR CINDER BLOCK WALL: (2) 3/8" DIAMETER x 3-1/2" LONG LAG WITH SHORT MASONRY EXPANSION SHIELDS*

*FOR DRYWALL: (2) 5/16" DIAMETER x 3-1/2" LONG T-STYLE HOLLOW WALL ANCHOR*

**ENPAC NOTES DRYWALL MATERIAL RECOMMENDATION, BUT DOES NOT ADVISE DUE TO LACK OF SURFACE STRENGTH.**

## MOUNTING INSTRUCTIONS:

- 1) FEED A WASHER ONTO THE SCREW OR BOLT YOU SUPPLY, THEN FEED ONE HALF OF THE STRAP ASSEMBLY ONTO THAT SAME SCREW OR BOLT. MAKE SURE THAT THE SHOW SIDE OF THE BUCKLE FACES YOU (See fig.1) FOLLOW STEP ONE FOR THE OTHER SIDE OF THE STRAP ASSEMBLY.(See fig.2)

FIG.1

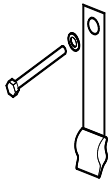
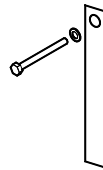

FIG.2



- 2) FOR BEST STABILITY RESULTS, MOUNT YOUR UNIVERSAL CYLINDER BRACKET APPROX. 2/3<sup>RD</sup> UP FROM THE FLOOR USING THE AVERAGE HEIGHT OF YOUR MOST COMMONLY USED GAS CYLINDER (See fig.3)

FIG.3

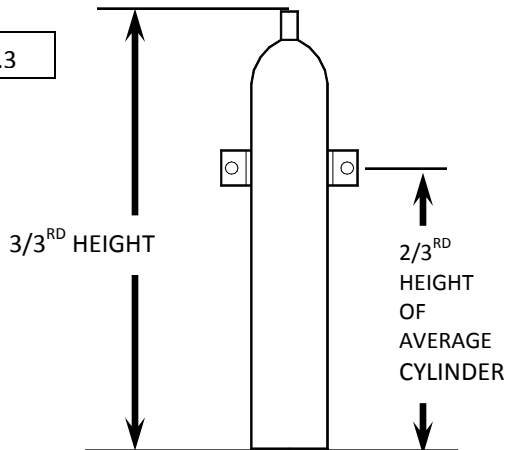
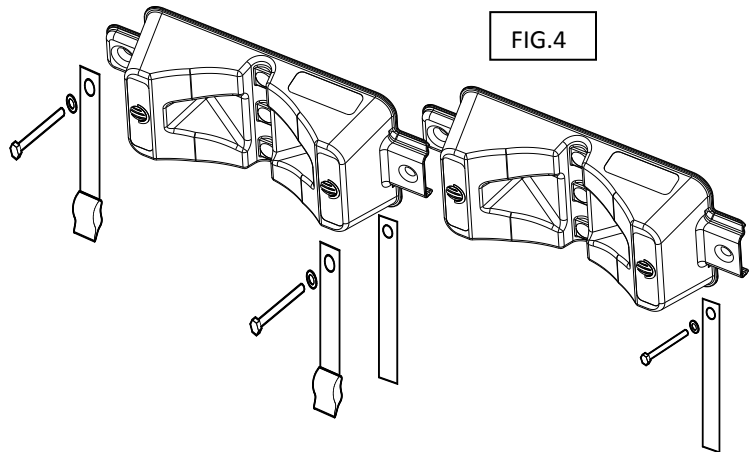

FIG.4



- 4) PUSH EACH BOLT AND WASHER THROUGH THEIR RESPECTIVE HOLES ON THE UNIVERSAL CYLINDER BRACKET AND PROCEED TO ANCHOR THE UNIT TO THE WALL OR MOUNTING SURFACE. IF MULTIPLE UNITS ARE BEING INSTALLED, THEY WILL OVERLAP AND LOCK TOGETHER WITH THE 2 STRAP ENDS BEING SECURED IN THE OVERLAPPING FLANGE. (See fig.4).

FOR MORE INFORMATION GO TO [WWW.ENPAC.COM](http://WWW.ENPAC.COM)