

GAS CYLINDER POLY STAND MODEL #7212-YE ASSEMBLY INSTRUCTIONS

THANK YOU FOR PURCHASING YOUR ENPAC GAS CYLINDER POLY STAND. THESE EASY INSTALLATION INSTRUCTIONS WILL ASSURE YOU STABLE AND SPACE-EFFICIENT GAS CYLINDER STORAGE.

SHIPPED PRODUCT CONTAINS THE FOLLOWING:

- (1) GAS CYLINDER POLY STAND
- (2) HEAVY DUTY NYLON STRAP ASSEMBLY

NOTE: HARDWARE USED TO MOUNT YOUR POLY STAND TO THE WALL IS NOT INCLUDED. YOUR MOUNTING SURFACE WILL DETERMINE THE HARDWARE USED FOR INSTALLATION.

ENPAC RECOMMENDS

FOR CONCRETE WALL: (3) 3/8" DIAMETER x 4-1/2" LONG LAG SCREW WITH MASONRY EXPANSION SHIELDS

FOR WOOD WALL: (3) 3/8" DIAMETER x 4-1/2" LONG LAG SCREW

FOR CINDER BLOCK WALL: (3) 3/8" DIAMETER x 4-1/2" LONG LAG SCREW WITH MASONRY EXPANSION SHIELDS

FOR DRYWALL: (3) 3/8" DIAMETER x 4-1/2" LONG T-STYLE HOLLOW WALL ANCHOR

ENPAC NOTES DRYWALL MATERIAL RECOMMENDATION, BUT DOES NOT ADVISE DUE TO LACK OF SURFACE STRENGTH.

MOUNTING INSTRUCTIONS:

- 1) FEED A WASHER ONTO THE SCREW OR BOLT YOU SUPPLY, THEN FEED ONE HALF OF THE STRAP ASSEMBLY ONTO THAT SAME SCREW OR BOLT. MAKE SURE THAT THE SHOW SIDE OF THE BUCKLE FACES YOU (See fig.1)

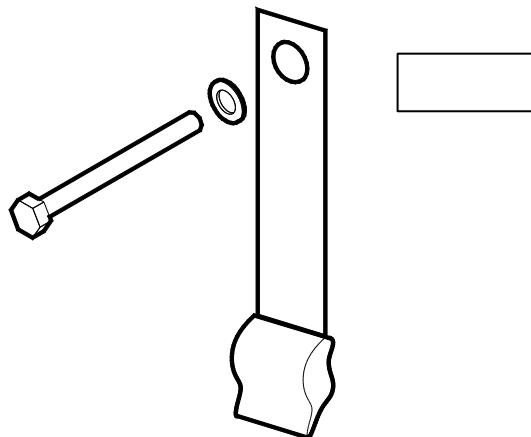

2) FOLLOW STEP ONE FOR THE OTHER SIDE OF THE STRAP ASSEMBLY.

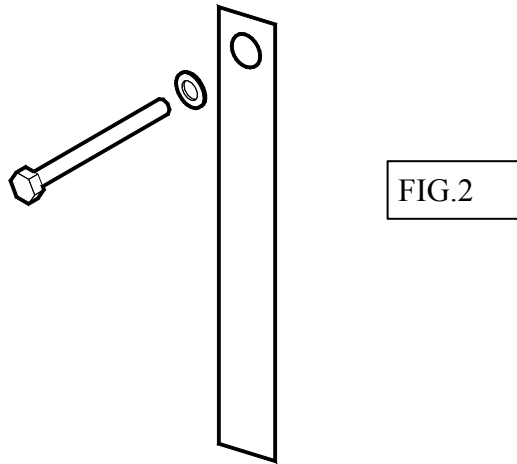

(See fig.2)

3) FEED A WASHER ONTO THE SCREW OR BOLT YOU SUPPLY, THEN FEED ONE COMPLETE STRAP ASSEMBLY ONTO THAT SAME SCREW OR BOLT. MAKE SURE THAT THE SHOW SIDE OF THE BUCKLE FACES YOU. (See fig.3)

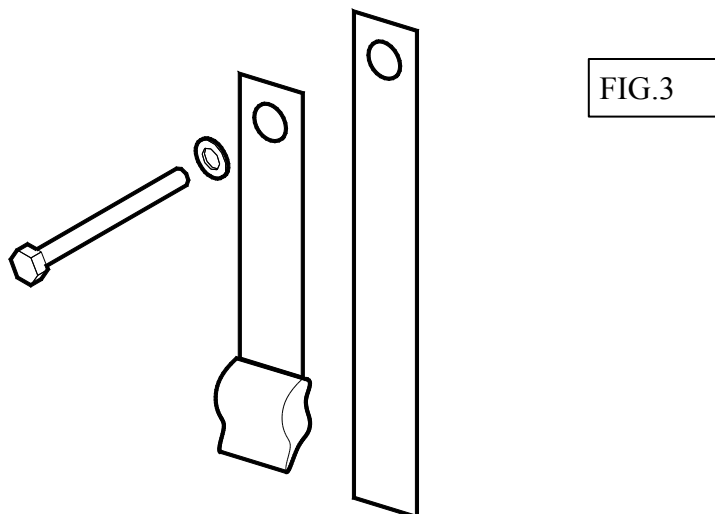

- 4) ONCE THE STRAPS ARE SETUP, PLACE THE POLY STAND AGAINST THE WALL OF YOUR CHOICE. MAKE SURE THAT THE PRODUCT RESTS FLUSHLY AGAINST FLAT SURFACE. (See fig.4)

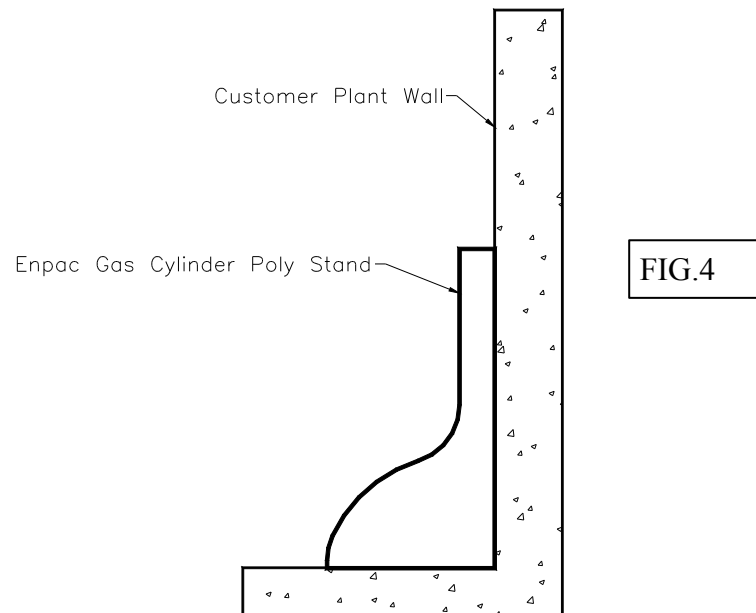

- 5) PUSH EACH BOLT THROUGH THEIR RESPECTIVE HOLES ON THE POLY STAND, THEN PROCEED TO ACHOR TO THE WALL (See fig.5).

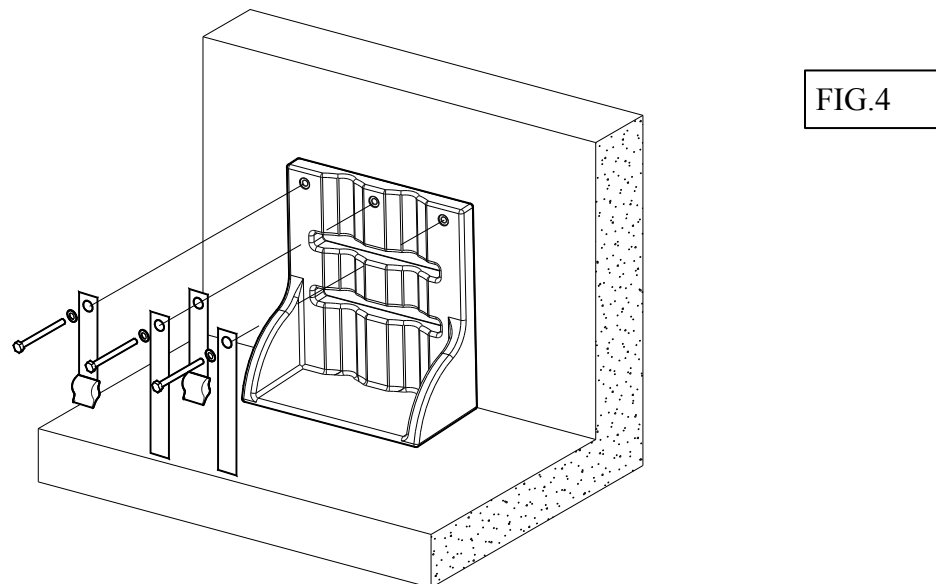

FOR MORE INFORMATION CONTACT ENPAC CUSTOMER SERVICE (800) 936-7229