

# POLY-SPILL CART

## ASSEMBLY INSTRUCTIONS

### Tools Needed:

Hammer  
1/2" Combination Wrench  
1/2" Socket Wrench

### Parts Included: (Inside sump for shipping)

1 Handle  
2 Rear Wheels  
2 Wheel washers  
2 Front Swivel Casters  
8 Each – 5 1/2" Bolts & Flange Nuts  
2 Axle caps

SOME SPILL CARTS WILL HAVE THE REAR WHEELS ON, WHICH AIDS SHIPPING. FOR THESE UNITS, PROCEED DIRECTLY TO PART 2. IF NONE OF THE WHEELS ARE ON, START WITH PART 1.

### **PART 1: WHEEL ASSEMBLY**

- PLACE A 2 WASHERS ON THE AXLE
- SLIDE A WHEEL ON THE AXLE. BE SURE HUB ON WHEEL IS TOWARD CART
- INSTALL A COTTER PIN INTO THE END OF THE AXLE AFTER INSTALLING THE WHEEL.
- REPEAT FOR THE OTHER SIDE
- COMPONENTS SHOWN BELOW

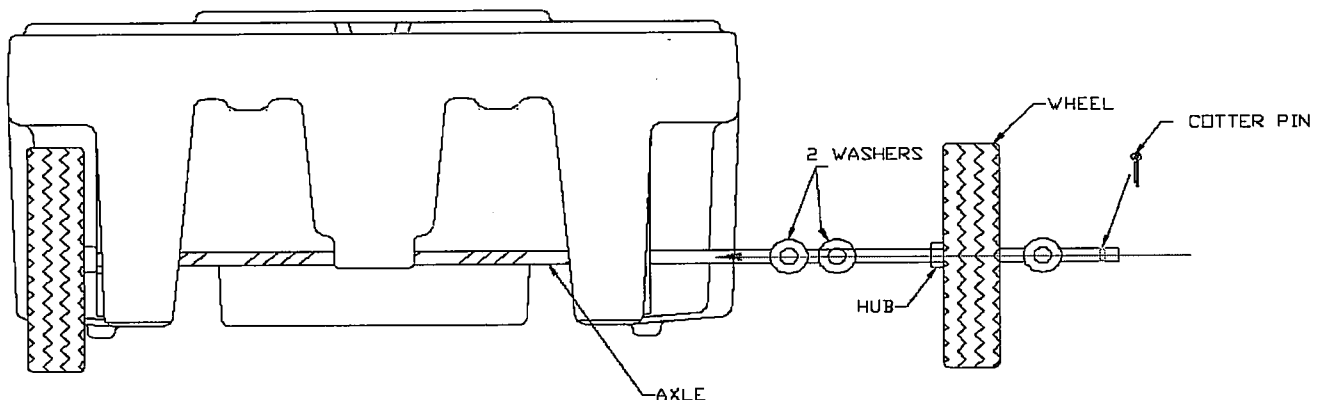

### **PART 2: HANDLE/CASTER ASSEMBLY (2 people recommended)**

- POSITION ENDS OF HANDLE IN MOLDED THROUGH HOLES ON TOP OF CART
- SLIDE HANDLE EVENLY THROUGH HOLES UNTIL FLANGES SEAT AGAINST CART
- TO INSTALL CASTERS, ELEVATE CART TO CONVENIENT WORKING HEIGHT
- INSERT A BOLT THROUGH THE HANDLE FLANGE.
- AS ONE PERSON HOLDS THE BOLT SECURE, ANOTHER PERSON MAY FASTEN A CASTER TO THE BOLT USING A FLANGE NUT (SEE PHOTO 1)
- LOOSELY THREAD THE NUT ONTO THE BOLT. **DO NOT** TIGHTEN NUT
- REPEAT THE ABOVE PROCEDURE WITH THE REMAINING 3 BOLTS. (IT MAY BE NECESSARY TO DIRECT THE LAST BOLT INTO THE CASTER USING YOUR FINGER (SEE PHOTO 2)
- USE THE 1/2" WRENCHES TO TIGHTEN THE CASTERS TO THE HANDLE
- REPEAT FOR OTHER SIDE

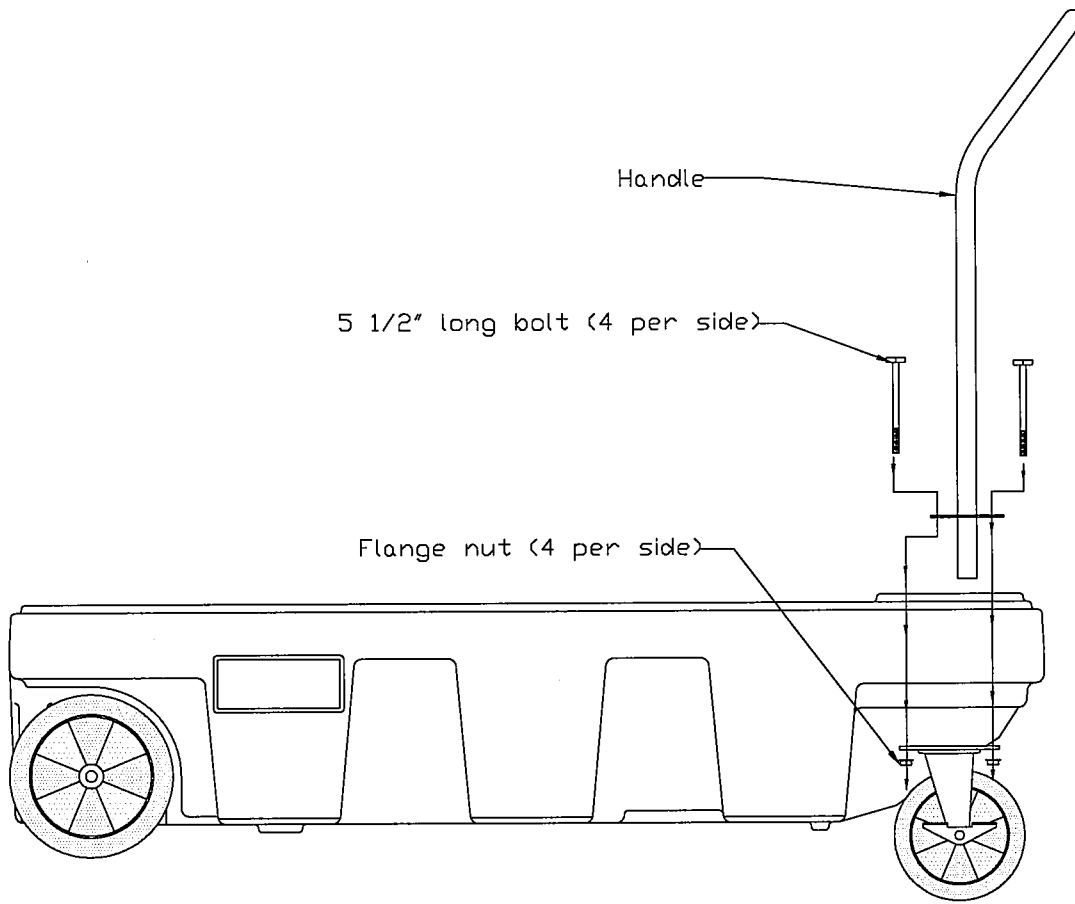

PHOTO 1

PHOTO 2

